

SGLARSTONE



Solar Full Roof™

BIPV module 430W FRS/SND EU-G2.5-3535-ABC N-type Bifacial

Full-size BIPV modules replace traditional roofing materials, creating a seamless, advanced solar roof. With clean, modern lines and integrated weatherproofing, it delivers maximum efficiency, durability, and beauty - redefining the roof as both a power source and an architectural statement.

Peak Power

430_{Wp}
~215 W/m²

Roof. Design. Power.

PRESERVE ROOF INTEGRITY

No drilling into rafters, preserving structural integrity and lasting weatherproofing.

FAST & EFFECTIVE INSTALLATION

Follows traditional roofing practices, allowing installation by a single roofing team.

LIGHTWEIGHT ON CONSTRUCTION

13.3 kg/m² lightweight 2-in-1 solar roofing lowers structural load.

EASY UPGRADE TO A/A+ ENERGY CLASS

Achieve A/A+ energy class without costly upgrades or design compromises.

FOR NEW BUILDS AND ROOF REPLACEMENTS

Cost-effective solar roofing for new construction or roof upgrades.



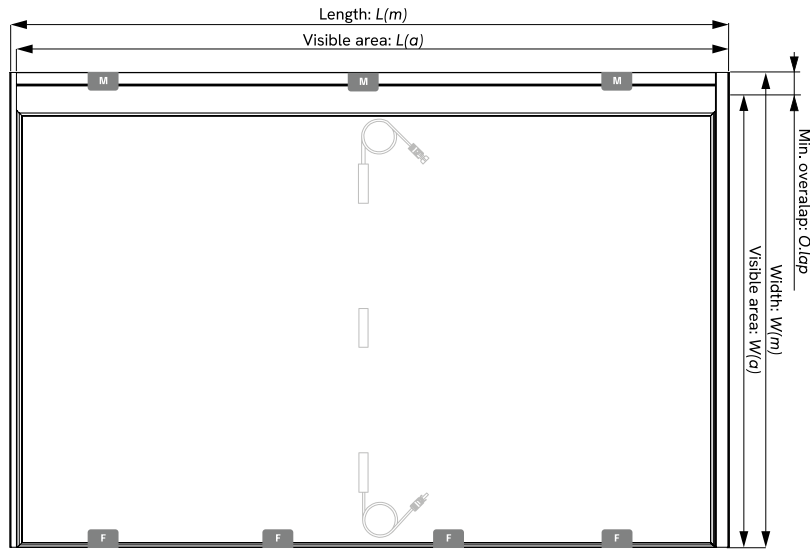

WORKING CONDITION	
Operating temperature	-40°C to +85°C
Mechanical loads (design load)	Snow: 5400 Pa (~550 kg/m ²)
	Wind: 2400 Pa (~224 kg/m ²)
Impact Resistance	HW 3 hailstones Ø 25 mm at 23.0 m/s (83 km/h)
Minimum Roof Slope	>18° slope (standard); 14-18° slope (with substructure)

PATENTS, CERTIFICATIONS & WARRANTY	
Patent	EP21736040A by SOLARSTONE
Fire Class Certification	EN 13501-5:2016: Broof (t1)
	EN 13501-5:2016: Broof (t2)
Wind Driven Rain	CEN/TR 15601:2012: Class B
EN Directives	IEC EN 61215:2021 - Design Qualification IEC EN 61730:2023 - Safety Qualification
Performance Warranty	30 years, on the 87% of the min. performance
Product Warranty	20 years
Designed & assembled in	Estonia, European Union (EU)

ELECTRICAL DATA	
Peak Power (P _{max})	430 Wp 215 Wp / m ²
PV Module	FuturaSun Silk® Nova Duetto All Black
PV Cells	108 monocrystalline half-cut MBB N-type bifacial cells 182 x 91 mm
PV Module Efficiency	22.0%
Maximum Reverse Current (I _r)	30 A
Maximum System Voltage (V)	1500 V
Open circuit voltage (V _{oc})	38.44 V
Short circuit current (I _{sc})	14.25 A
Maximum power voltage (V _{mpv})	31.86 V
Maximum power current (I _{mpv})	13.50 A
Number of bypass diodes	3
Junction box	SY-898: IP-68, Class-II, DC-1500V
Junction box cable	110 cm; 4.0mm ²
Electrical connector	Mc4 Connector (Xtong Tech, PV-XT101.2)

MECHANICAL SPECIFICATIONS	
Glass	Front: 2.0 mm solar glass with ARC, DIN EN 1863-1/-2 Back: 2.0 mm heat strengthened glass, DIN EN 1863-1/-2
Encapsulate	Co-extruded EVA/POE/EVA film layers, film thickness 0.50 ± 0.10mm
Frame	Anodized Aluminum frame (Black, RAL9005), 35x35mm

MEASUREMENTS						
Model	External dimension	Weight	Visible area	Overlap	First	Middle
LND-A:	1791 x 1195 x 35 mm	~28 kg 13 kg / m ²	1754 x 1140 mm	55 mm	1070 mm	1140 mm
LND-B:	1791 x 1245 x 35 mm		1754 x 1190 mm	55 mm	1120 mm	1190 mm
LND-C:	1791 x 1295 x 35 mm		1754 x 1240 mm	55 mm	1170 mm	1240 mm

MODEL	SKU CODE	PACKAGE
BIPV module LND-A	SFR-A121211.V1	PLL: 24 pcs; 1850 x 1100 x 1400; 800 kg
BIPV module LND-B	SFR-B121211.V1	PLL: 24 pcs; 1850 x 1100 x 1400; 800 kg
BIPV module LND-C	SFR-C121211.V1	PLL: 24 pcs; 1850 x 1100 x 1400; 800 kg

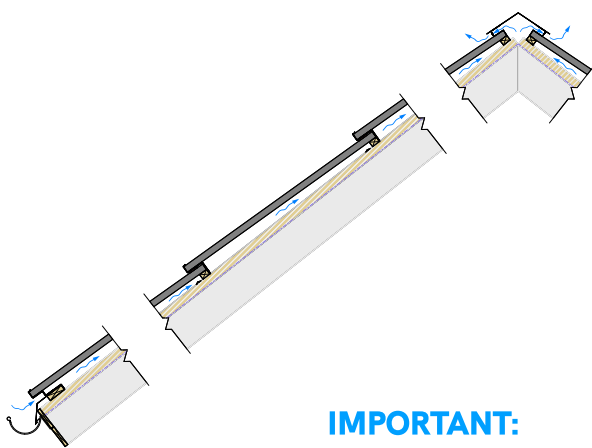

IMPORTANT:

Please read safety and installation instructions before using the product. Use only underlayment membranes specifically designed for PV panel installations, providing watertightness, UV resistance, and suitability for temperatures from -40 °C to +120 °C, in accordance with the EN 13859-1:2014 standard. Use only with inverters with Arc-Fault Circuit Interrupter (AFCI).



YouTube
Watch the installation of Solar Full Roof™

Roof.
Design.
Power.

Member of:

